

EU

2004. 6



: (가)

: ()

()

()

()

()

(가)

1.	(REACH)	1
1.1.	REACH	1
1.2.	REACH	3
2.	REACH	7
2.1.	EU	7
2.2.	가 가	9
3.		7 2
3.1.	EU	27
3.2.		28
4.		1 3
4.1.	REACH	31
4.2.	EU	42
5.	REACH	9 4
5.1.		49
5.2.		51

6. REACH 6

< > 6

..... 65

.	67
. EU	(REACH)	71
. REACH	177
.	189

< 1> EU	2
< 2>	4
< 3> EU	8
< 4> Chemical Safety Report	>	23
< 5> 가 가	25
< 6> 2003 EU	43
< 7> REACH	44
< 8> 가 , 가	46
< 9>	47
< 10> GLP 가	48
< 11>	56

[1] REACH	9
[2] REACH	31
[3] REACH	>	32
[4] EU	33
[5] REACH	33
[6] REACH	34
[7]	35
[8]	35
[9] EU	Data	36
[10]	37
[11]	38
[12] EU	38
[13]	EU	39
[14] EU	40
[15] REACH	40
[16] REACH	41
[17] REACH 가	42

EU (REACH ; Registration, Evaluation, and Authorization of CHemicals)

, 가 .
REACH .

" No data, no market. "

REACH가 2001 3 . REACH
REACH
REACH

REACH

REACH

REACH가 가 Data 가

Networking

REACH가

Abstract

On October 29, 2003, the European Commission adopted a proposal for a regulation concerning chemicals. The proposed Regulation would replace over 40 existing Directives and Regulations. Its main feature is the creation of the REACH regime. REACH, an acronym which stands for Registration, Evaluation, and Authorization of Chemical Substances, imposes obligations on EU manufacturers and importers of chemicals and of all other tangible products (1) to compile and file comprehensive reports, including testing data, on each substance (so called "registration"), (2) to assess the safety of each substance ("chemical safety assessment"), (3) to obtain use and applicant specific authorization, subject to conditions, with respect to certain chemicals, and (4) to comply with any restrictions on the manufacture and use of restricted chemicals.

The problems are the businesses do not understand what the real REACH is and they do not recognize the seriousness of it. Most of small businesses would rather quit exporting the chemicals than registering with paying expensive test and registration fee unless they could make more money.

To encourage businesses, provided are the general plans. Some preparatory plans are (1) to designate a focal point that can guide all about REACH, (2) to centralize the scattered data around the organizations, (3) to construct and support laboratories according

to GLP standard with educating and training the personnels needed, and so on.

Apart from the impacts of REACH, it is very certain that protection of the human health and the environment are to be improved, and the access to information on chemicals is to be facilitated. Now it is time for businesses to consider sustainable development considering both development and the environment.

1

(REACH)

1.1. REACH

2001 2 , EU REACH(Registration, Evaluation, and Authorization of CHemicals) 가

2 REACH

. EU 5 7 8

REACH 가 . 6,000

10 29 EC(European Commission)

EU (1981 9 18

2,700) (1981 9 18

100,100) , 10kg ,

1 30,000

(downstream users)

. REACH 40

가
 가
 REACH , 가, 가
 가
 가
 EU
 < 1> EU

2001. 2	White Paper on a Strategy for a Future EU Chemicals
2002. 3	Working Groups
2003. 5. ~ 6.	Third Parties Reports
2003. 5. 7	(Commission Discussion & Press)
2003.5.15~7. 10	
2003. 9	Intra - Service Consultation
2003. 10. 29	(Final proposal)
2005~2006	

EU "The Dangerous Substances Directive 67/548/EEC(DSD)" , 가
 가 (, , 가,
) REACH
 가 가 . EU 2003 5 7 REACH

2003 10 29 . REACH
EU (1)
(Authorization) (Registration), 가(Evaluation),
, (2) 가
, (3)
EU , EU

1.2. REACH

1981 (2,700)
(100,100) , 10kg
30,000 .
2 10
가 가 . 가 가
가

< 2 >

(EINECS)	100,000
HPV	2,500
LPV	8,500
가 (priority substances)	110
가가	20 ~ 30

*EINECS : European INventory of Existing Commercial Substances

*HPV : High Production Volume chemicals

*LPV : Low Production Volume chemicals, Ref.12

EU 가 , 가 .

가) (가 10kg 1 가 .

가 .

가

2

REACH

2.1. EU

EU 2003 5 7 가
 , 8 .('03. 5. 16~'03. 7. 10)
 Website , .
 Registration(), Evaluation(가), Authorization(
) .
 가 ,
 . , 가 ()
 .
 , ,
 가 가 .
 가
 , .
 가 , , (CMRs),
 (persistent, bioaccumulative and toxic substances
 ; PBTs) (very persistent and very bioaccumulative
 substances ; vPvBs) 가 가
 가 가 가

가 가 .

-
- 가
-
-
-
-
- 가
-
-
- EU

< 3> EU

		()
가		()
가	(가 EU)	
	(, OECD SIDS)	, 가 ,
	()	/ 가/ 가
/ 가/ 가		
Downstream user		(/)
가		

* SIDS(Screening Information Data Sheet), Ref.13

2.2. 가 가

2.2.1.

REACH (Evaluation), 가 (1) EU (Authorization), (Registration), 가 (2), (3)

EU, EU 2

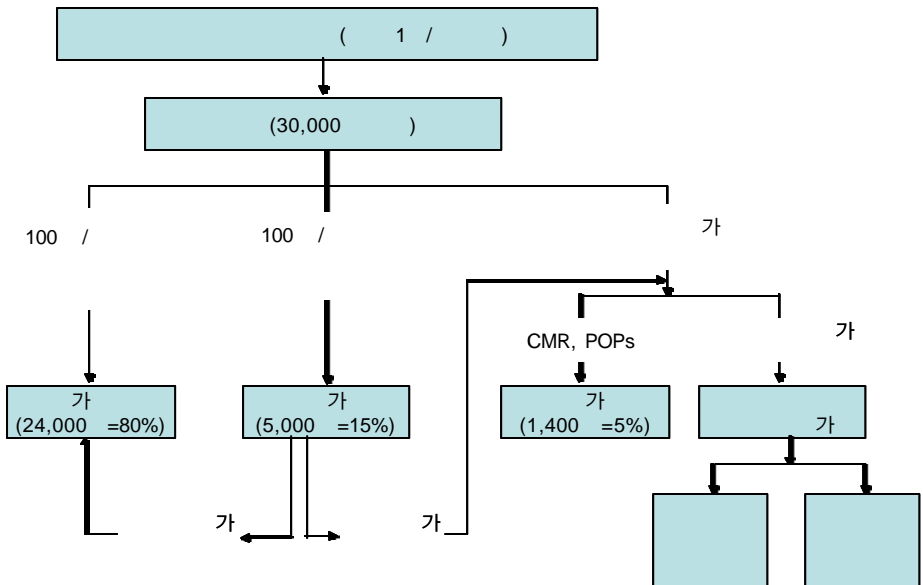

[1] REACH

2.2.2.

REACH 가 ECA(European Chemicals Agency ;
)가 . EU 1 .
 ECA . ECA (Registration Dossier)
 Database .
 ECA Spot check . 30,000
 , 80% 가 가
 . 100 5,000
 가 , 가 .
 100 , Level 1
 . , 가 .
 ECA , 가
 . Level 1 가 1,000
 , Level 2 . 가
 . Phase-in
 가 (draft decision) 1 CMR 1000
 5 , 100
 9 .
 가 ,
 , , , , ,
 , (Chemical Safety Report) ECA 가
 (update) . ECA ,
 Database 가 .

- , , , flow modifier, pH , ,
- , , , , ,
- ,
- 가 ,
- Directive 67/548 ,
- 가 , ,
- EU (EU)
- EU
- EU 30 31 가
- Non-isolated ()
- Monomer(Article 5, Paragraph 2)
- On site isolated (Non-isolated 가 site
- .) Transported isolated (Non-isolated site
- , 3 site 3 site)
- 가 .
- Polymer(Article 5, Paragraph 3)

- 가 2 wt%
- 1t/y
- (Article 8)
biocide active ingredient
- (Article 6)
(Article 6, Paragraph 1).
- 1 t/y ()
- Directive 67/548/EEC
-
- Paragraph 3
- (notify) .
- 1 t/y ()
- Directive 67/548/EEC
- ,
- , Article 108
- 가 , Article 18
- (Annex IV Section 2)
-
- (, 1~10 t, 10~100 t)

ECA

가

Article 21 deadline 3
가 Article 130

- (Article 15, 16)

Non - isolated . On site Transported
isolated . 1 t/y 가
가

(Annex IV Section 1), (Annex IV Section 2), , 가
(,)

transported isolated 1000 t/y Annex V
가

- (Article 7)

R&D(process-oriented research and development ; PORD)

5 (, 가 5
가). ECA , (label),

, (research program) Customer
. PORD ,

EU (Article 6a)

EU , EU
, EU

REACH

EU

가

Up - date

MSDS

, EU

(Downstream user)

- CMRs(1t/y) : 3

▪ 1,000 t/y : 3

▪ 100 t/y : 6

▪ 1 t/y : 11

DSD Scheme(Dangerous Substances Directive 67/548/EEC)

REACH

가

(Article 9)

가 , Chemical Safety Report(

) Technical Dossier()

o Technical Dossier()

Technical Dossier 가 ,

Annex IV~

- (Annex IV)
- (Annex V~)
-
-
-
- , 가
- , Annex V~

Robust study summaries 가
가

Technical Dossier

Annex IV , Annex V~
, EU

Annex

- Annex V : 1 t/y 10 t/y
- Annex VI : 10 t/y 100 t/y
- Annex VII : 100 t/y 1000 t/y
- Annex : 1000 t/y

Annex V~ column 1 , column 2

column 1 가 .

Annex IV Annex V~

1 t/y 10 t/y , ,

, gap ,
 100 t/y 1,000 t/y 가 .
 in vitro
 , GLP .

o Chemical Safety Report()

Chemical Safety Report

(PBT vPvB) 가 . Chemical Safety Report

Annex I(General Provision for Assessing Substances and Preparing
 Safety Report) . 10 Chemical
 Safety Report 가 .

Technical Dossier ECA가 (가 , IUCLID :
 International Uniform Chemical Information Database, ref.15) Standard
 electronic format . ECA 가 software
 package Chemical Safety Report

. food-contact

EU 가 Chemical Safety Report

가 가 .

(Annex V~) ,

non-standard non-GLP , , weight of evidence,
 SAR(Structure Activity Relationship)

Annex IX

. Annex VII Annex 가

" - "

가 .

90%

Chemical Safety Report 가 ,
CSR , ECA
가 .

ECA , EU
Database 가 Database

(enquiry) . , 10
. 10

50%

Phase - in Deadline 18

가 .
, 가 . Phase - in

Substance Information Exchange Forum(SIEF) 가

- / - 가 가 .

1 t/y

1 t/y

, 가 가

- & EINECS

-

-

- & SDS

-

-

-

ECA

Chemical Safety Report(CSR)

EU REACH

가

Chemical Safety Report

가

가

가

가

Chemical Safety Report

Annex

I

Annex I Section 7(7)

-

-

가(Chemical Safety Assessment)

가

- 가
(life cycle) , ,
가
- 가(Chemical Safety Assessment) Technical
Dossier 가 ,
Annex I Section 1~6 .
- Section 1~4 PBT vPvB
, Section 5 6 가 .
- 가(Chemical Safety Assessment)
가 .
- Chemical Safety Report ,
, 가
가 가
가
- EU Community 가
- Annex I Section 1~6
가 가

Annex VII

Chemical Safety Report

- 가
- 가
- 가
- PBT(persistent, bio-accumulative, toxic) vPvB(very persistent, very bio-accumulative) 가
- 가
-

Chemical Safety Report

가

2.2.3. 가(Evaluation)

100 (5,000 , 15%) 100
 , , , (CMRs) . /
 .
 , 100
 가 . 가
 ,
 가 .

2.2.4. (Authorization)

가
 가 . 1,400 가
 . Step 1 가
 , 가 가 . 가
 , 가 가
 . 가 가
 life-cycle 가 Step 2 가 가
 가 , ,
 . EU , EU
 가 , 가가 , 가 가
 . , 가
 . 가 1 2 ,
 , (850 500)
 가 , PBTs, vPvB, 가
 가 . POPs

< 4> Chemical Safety Report >

Chemical Safety Report

[1]

- 1.
- 2. 가
- 3.

[2]

- 1.
- 2.
- 3.
- 3.1.
- 3.2.
- 3.3.

[3]

- 1. 가
 - 1.1. ,
 - 1.2.
 - 1.3.
 - 1.3.1.
 - 1.3.2.
 - 1.3.3.
 - 1.4.
 - 1.5.
 - 1.5.1.
 - 1.5.2.
 - 1.6.
 - 1.7.
 - 1.8.
 - 1.9.
 - 1.9.1.
 - 1.9.2.
 - 1.10.

2. 가

2.1.

2.2.

2.3.

3. 가

3.1.

3.2.

3.3.

3.4.

4. PBT vPvB 가

5. 가

5.1. 1

5.2.1.

5.2.2. 가

5.2. 2

5.3.1.

5.3.2. 가

6.

6.1. 1

6.1.1.

6.1.1.1.

6.1.1.2.

6.1.1.3.

6.1.2.

6.1.2.1. ()

6.1.2.2.

6.1.2.3.

6.1.2.4.

- 6.2. 2
 - 6.2.1.
 - 6.2.1.1.
 - 6.2.1.2.
 - 6.2.1.3.
 - 6.2.2.
 - 6.2.2.1. ()
 - 6.2.2.2.
 - 6.2.2.3.
 - 6.2.2.4.
- 6.x. (/)
 - 6.x.1 ()
 - 6.x.1.1
 - 6.x.2 ()
 - 6.x.2.1

< 5> 가 가

가 (Evaluation)	- 100 , - 100 (, , , ,) , ; QSAR	- Registration - : <100 - 1000 Annex VII> <1000 Annex VIII>
(Authorization)	- Very High Concern CMRs(, , , ,Cat1/Cat2); POPs; PBTs, VPVBs;	- 가 (R&D , 가)

3

3.1. EU

EU 2003. 5. 7. ,
가 , 8 (: 5.
16~7. 10) , 2003 11 29
. REACH
가 1 , 가
가 .
EU
, 3 ,
.
- : .
가 ,
- 3 : 3 3 ,
- : .
/ 가 가 .
가 가 가 .

- N G O :

(BBUC)

NGO

NGO가 가

가 가

3.2.

REACH 가

EU가

White Paper

2001

EU

가

, APEC

Chemical Dialogue

WTO

(Toxic Substances Control Act)

가 (Q)SAR

ACC(CMA,

American Chemical Council)

. ACC (www.amircanchemistry.com)

REACH

EU

, WTO TBT(Technical Barrier to Trade)

(JCIA, www.nikkakyo.org) JETOC

(JCIA가 1978

, www.jetoc.or.jp)

JCIA가

REACH
10
Task force
가
JETOC REACH
가
, White paper가
가
REACH
가 2003 9 20
EU (substantial change)
REACH
REACH가
가
(BDI,
www.bdi-online.de) REACH 170
가 REACH
가
(UNICE) EU 가 REACH
가
REACH
EU (Competitiveness Council)가
CEFIC(www.cefic.be) 가

가

REACH

BCDTA(www.bcdta.org.uk)

REACH가 가 (risk)
가 (hazard) ,
가

(downstream user) REACH가

가

가

가,

EEB(European Environmental Bureau, www.eeb.org), Friends of the Earth(www.iefi.org), Greenpeace(www.greenpeace.org)

4

4.1. REACH

o REACH

REACH 44%

10%

24%

REACH 가

REACH

가

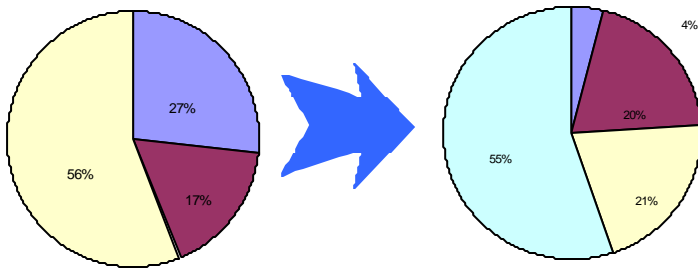

[2] REACH

o REACH

REACH

가 가 62%

11%

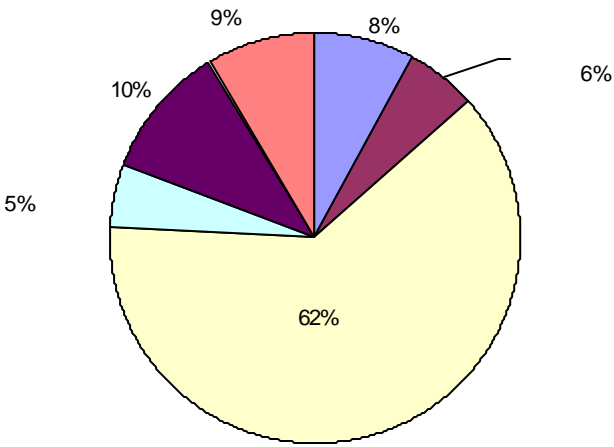

[3] REACH

>

o

REACH

31%

REACH

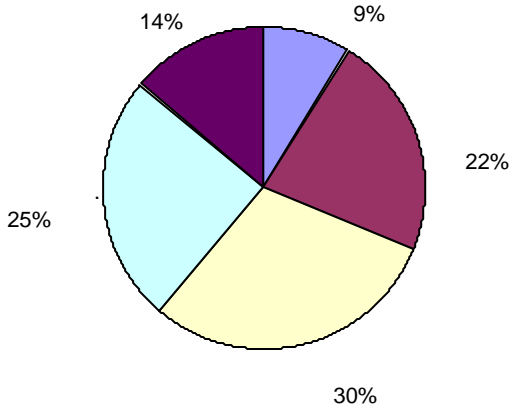

[4] EU

o REACH

REACH

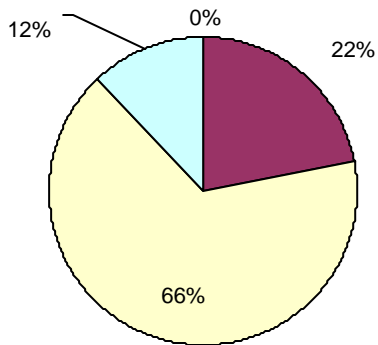

[5] REACH

o REACH

REACH

가

'EU

(REACH)

' REACH

()

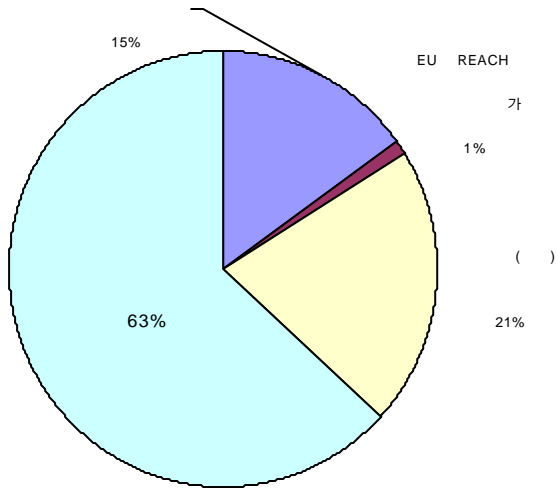

[6] REACH

o

74%가

가

REACH가

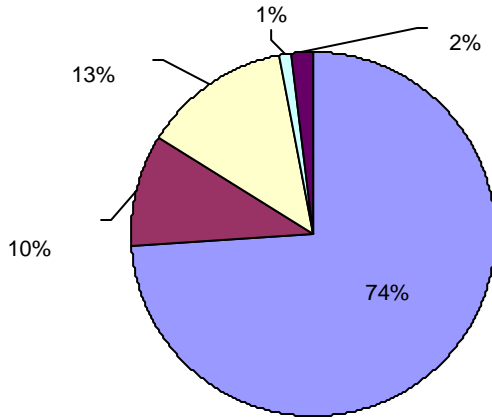

[7]

0

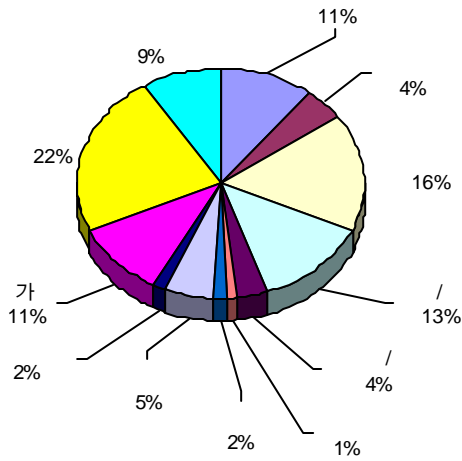

[8]

EU Data

Data가

37%

가

Data가

가

가

가

가

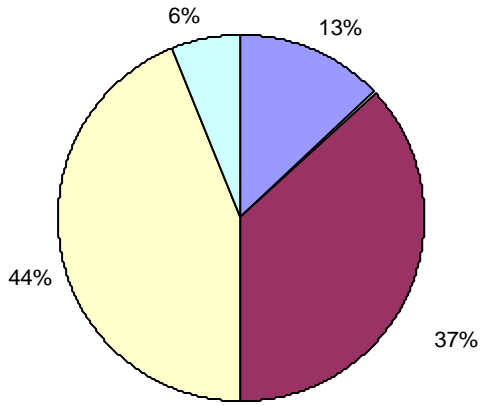

[9] EU

Data

()

MSDS()가

Data

Data

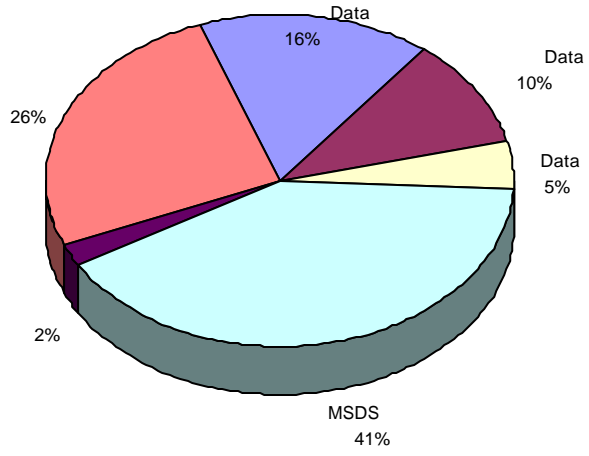

[10]

0

()

DB

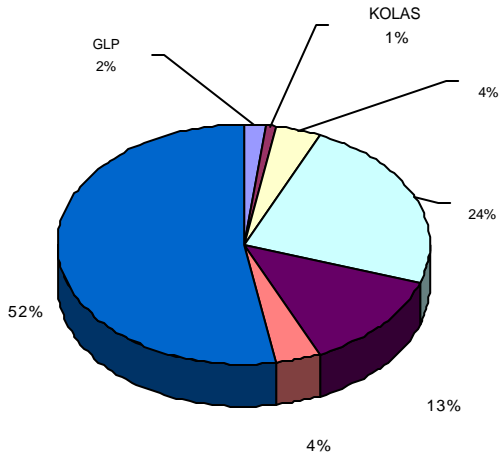

[11]

o EU

47%

REACH

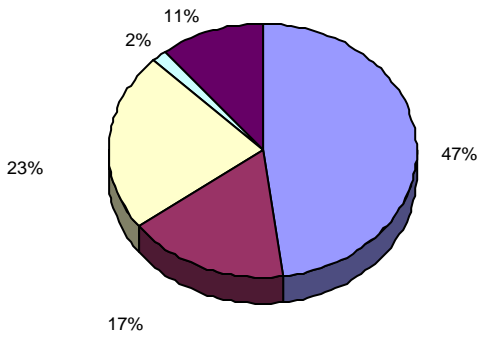

[12] EU

0 5 4
EU
63%가
가
가
2003 EU 가 12

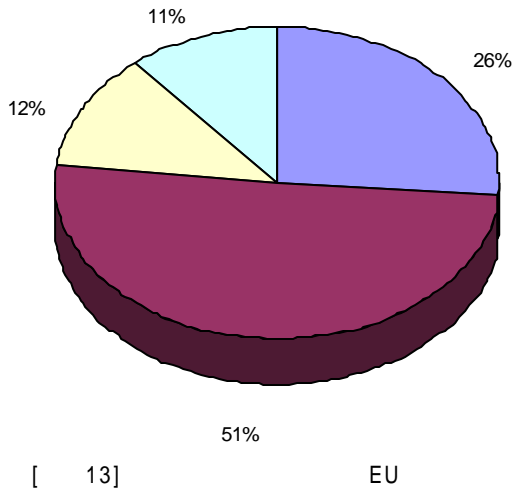

o EU

가 WTO
,
,
, 가 EU

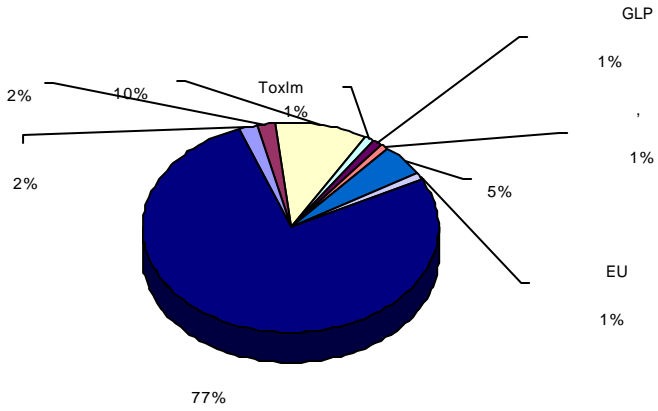

[14] EU

o REACH

REACH

가 가

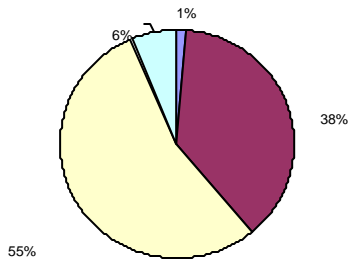

[15] REACH

○ REACH

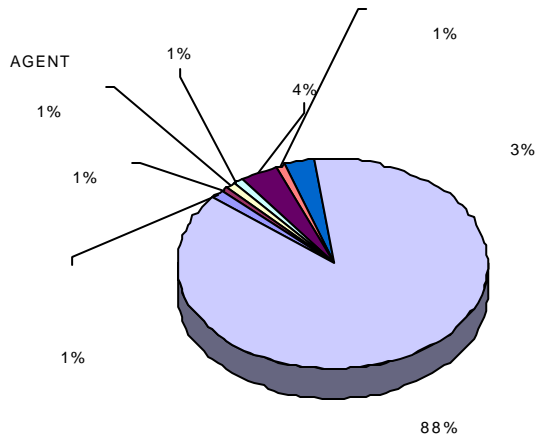

[16] REACH

○ REACH ()

REACH 가

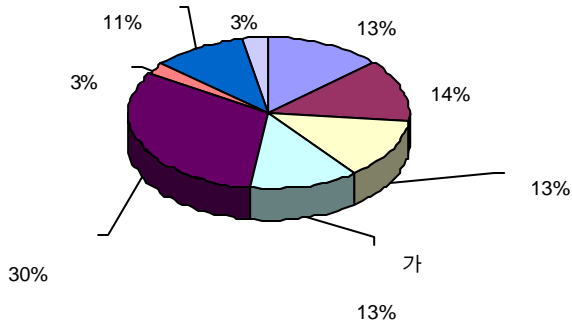

[17] REACH 가

4.2. EU

4.2.1.

가 2002 EU 11 3
 () 185 6%
 가 , 10 가

EU

EU REACH

가 가

, EU 가 . EU

가

,

.

, EU REACH

10

1

< 6> 2003

EU

(:)

		EU	(%)
()	12,479	849	5.2
()	5,050	412	8.2
()	1,202	68	5.7
	18,531	1,129	6.1

4.2.2. REACH

EU , 350
600 EU . 가 1,000
13 100 87 ,
10 169 . 7
. 10 169 , 100
1 가 87 , 1,000 2 가 13
.
.

< 7 > REACH

			(x)	
10 t/y	169	(1~17)	2,873	17 × 169
		(22~29)	1,352	8 × 169
		(36~43)	1,352	8 × 169
			5,577	
100 t/y	87	(1~21)	1,827	21 × 87
		(22~32)	957	11 × 87
		(36~49)	1,218	14 × 87
			4,002	
1000 t/y	13	(1~21)	273	21 × 13
		(22~35)	182	14 × 13
		(36~53)	234	14 × 13
			689	
			10,268	

*

- 1: , 2: / , 3: , 4: , 5: , 6: ,
 7: , 8: , 9: , 10: , 11: , 12: ,
 13: , 14: , 15: , 16: , 17: ,
 18: , 19: , 20: , 21: ()

*

22: in vitro , 23: , 24: in vitro , 25: in vivo ,
 26: , 27: (28), 28: , 29: Toxicokinetics,
 30: in vivo , 31: (90), 32: 2 , 33: 가 ,
 34: (12), 35:

*

36: , 37: , 38: , 39: ,
 40: , 41: 가 , 42: , 43: / ,
 44: , 45: , 46: , 47: ,
 48: , 49: . 50: ,
 51: , 52: , 53:

< 8> 가 , 가

가		가	가	()
		10	269	26.9
		20	269	13.5
		20	269	13.5
		80	269	3.4
		568	269	0.5
		775	269	0.4
		62	269	4.3
	28	100	269	2.7
	90	75	100	1.3
	12	42	13	0.3
		38	269	7.1
2		3	100	33.3
in vitro		480	269	0.6
in vivo		160	100	0.6
		18	13	0.7
		70	269	3.8
		50	269	5.4
		50	269	5.4
		60	269	4.5
가		10	269	26.9
/		10	269	26.9
		12	100	8.3
		6	100	16.7
		5	100	20
		15	100	6.7

< 9 >

EU				
10t/y	169		1.6	$169 \times 1.6 = 270$
100t/y	87	1 가	4.5	$87 \times 4.5 = 392$
1000t/y	13	2 가	10	$13 \times 10 = 130$
Total				792

가 가 .

4.2.3. REACH

EU REACH 가 GLP

가 .

GLP

가 ,

LG ,

GLP

가 ,

< 10> GLP 가

	EU	가	
	21	1	,
	14	14	, ,
	18	5	, ,

가가 REACH

REACH Annex

GLP

, GLP

(,) GLP

(KOLAS)

가

,

.

5

REACH

5.1.

o EU REACH
- EU

가

- EU

GLP

GLP

, GLP

-

REACH

,

o 가

- EU

1

-

(,)

EU

가

1

(notification)

- , 가
Chemical Safety Report 가 가 ,
가 .
- , REACH 가 ,

- o REACH 가
- REACH
가 , EU .
- 가 ,
- , EU
가 가 ,

- o EU EU
Chemical Safety Report .
- EU
가 .
- , 가 .
- EU 가 ,
가 .

- GLP 가 가 가
- 가 가
- Data 가 .
- 가 가
- .

○ REACH

- 가 가 .

5.2.

5.2.1.

- .
- .
- 가 가 .
- 가 .

0 가 가

- 가 REACH

가
가 가

0

- 가

5.2.2.

0 T/F REACH

- 가

- 2003 11
가가 EU REACH

, , DB , REACH

0

EU () ,

, ,

.

.

0

,

, .

.

0 EU

EU EU EU
가 , EU

.

.

, 가 EU

.

,

.

0

, 가

.

,

50%

o

EU

,

Database,

Database

,

가

.

,

SAR(Structure-Activity Relationships)

o

/

Gap

,

가

, QSAR

.

,

.

o Chemical Safety Report

Chemical Safety

,

Report

EU

o

가

,

가

가

가

,

가

,

가

가

,

EU

.

0

- 가

▪ GLP

▪

KOLAS

- 가

0

- EU

)

T/F

- 가

가

가

- EU

EU

5.2.3.

- REACH 가 ()

-

-

Sheldon E-factor () REACH

() 가

(green chemistry)

가

< 11 >

		kg /kg (E-factor)
Bulk Chemicals	$10^4 - 10^6$	1 - 5
Fine chemical industry	$10^2 - 10^4$	5 - 50
Pharmaceutical industry	$10 - 10^3$	25 - 100

*R.A. Sheldon, Chem & Ind, 1997, 12; 1992, 903

o (Alternative synthetic pathways)

-
-
- ,

o (Alternative solvents)

-
-
-
- (Solvent - free)
-

o (Biotechnology alternatives)

-
-
-

o (Nanotechnology alternatives)

-
-
- .

o

-
-
-

- - , VOC
- Green Chemistry

0

- - , formulation
 - 가

0

- 가 EU
- Plastic 가 (Pb, Cd, Halogen)
 - 가 가 가
- - (), Hair Dyes
 - Amine
- - Cellulose 5%~15%
- - (,)
- Ink
- - 가 .
 - , 가
 -

-
- 가
- :
-
-
-
-
-
- (waterborne), (high solid), (powder coating)
- VOC
- VOC
-
-
- (NOx, SOx)
- Free (Pb-free , Tin-free)
-
- 가 가
- 가
- /

0

-

,

▪

-

▪

-

-

가

REACH

REACH

REACH

가

가

Data

가

Networking

REACH가

< >

1. , EU REACH , , 2003.
2. 가 , EU (REACH) , 2003.
3. , EU REACH , , 2003.
4. , EU REACH GHS , 2003.
5. , EU REACH ,2003.
6. , 가 , EU REACH () , 2003.
7. (<http://www.amircanchemistry.com>)
8. (<http://www.jetoc.or.jp>)
9. (<http://www.nikkakyo.org>)
10. (<http://www.cefic.be>)
11. (<http://www.bcdta.org.uk>)
12. European Chemical Bureau(<http://ecb.jrc.it/>)
13. OECD SIDS(<http://www.epa.gov/opptintr/chemrtk/sids101c.pdf>)
14. EU REACH (<http://europa.eu.int/comm/enterprise/chemicals/chempol/whitepaper/reach.htm>)
15. European Chemicals Bureau, Course on IUCLID and REACH - it, 2003.
16. , (REACH) , 2003.11.

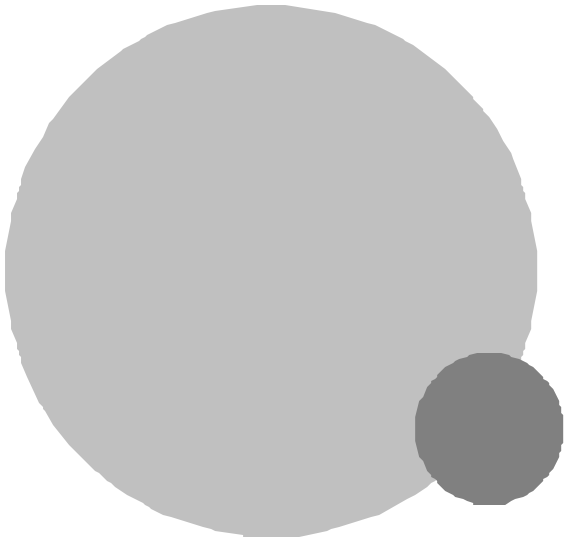

1.

2. EU

3. REACH

4.

(REACH) ()

1

- 가(Business impact assessment) : 가 REACH
- (Existing chemicals) :1981 9 18
- (Endocrine disrupters) :
가
CMR
- (Exposure) :
- (Substitution) :
- (Toxicity) : 가,
- (Animal testing) :
- (New chemicals) : 1981 9 18
- (Risk) :
- (European Chemicals Bureau) :
(JRC Joint Research Centre)
- (Competent Authorities) :REACH

- (Article) : 가 (:)
- (Substances in articles) :
- (Intermediates) :
- (Tonnage threshold) : REACH
- (Downstream user) :
- (IFCS, Intergovernment Forum on Chemicals Safety)
- CMR : (Carcinogenic), (Mutagenic) (Reproductively - toxic). CMR 1,2 가
- ECA(European Chemical Agency) : REACH
- EINECS : European INventory of Existing Commercial Substances, EU
- GH S : Globally Harmonised System for classification and labelling of chemicals
- GLP(Good Laboratory Practice) :
- HPV : High production volume chemicals
- IUCLID (International Uniform ChemicalL Information Database) : 가 Database
- LPV : Low Production Volume chemicals
- MSDS(Material Safety Data Sheet) :

-
- PBT s(Persistent bio -accumulative Toxic Substances) :
가 .
 - PIC(Prior Informed Consent) :
(PIC)
 - POPs(Persistent Organic Pollutants) : . UNEP
 - Preparation :
 - (Q)SAR(Structure Activity Relationships) : Q quantity quality
 - R&D (PPORD, Product and process oriented research and d evelopment) : R&D
 - SIDS(Screening Information Data Sheet) : OECD 가
" 가 "
 - vPvB(very persistent, very bio -accumulative) :

2

EU

(REACH)

TITLE .

CHAPTER 1.

1

1. 3 (1)

2.

3.

2

1.

(a) Council Directive 96/29/Euratom

(b) 가

(c) non - isolated

2. :

(a) Council Directive 89/391/EEC

(b) Directive 90/394/EEC

(c) Council Directive 98/24/EC

(d) , , ,
Community

CHAPTER 2.

3

:

1. (substance) 가

2. (preparation) 가

3. (article) / ,

4. (Polymer) 가 (monomer units)
(sequence) (molecules)

(a) 50% 1 Polymer :

13. (distributor) , 3 ,
Community

14. (intermediate) , (, "
(synthesis)" .)

(a) non - isolated (sampling)

batch

(b) on - site isolated non - isolated
가 site

(c) transported isolated non - isolated
3 site 3 site

15. Site 가 ,

16. (actors in the supply chain) /
/

17. (communicate down the supply chain)

가

18. (communicate up the supply chain)

가

19.

20. phase-in (phase-in substance) 15

(a) Community 2004 5 1 가 가

European Inventory of Existing Commercial Chemical Substances (EINECS)

(b) Community 2004 5 1 가 가

(c) Community 2004 5 1 가 가

, 1981 9 18 1993 10 31

, Directive

79/831/EEC Directive 67/548/EEC 8 (1)

(first indent)

Directive 92/32/EEC Directive 67/548/EEC

polymer

21. (notified substance) 가

Directive 67/548/EEC

- 22. (product and process oriented research)
가
,
(pilot plant) (production
trial)
- 23. (scientific research and development) 1
,
- 24. (registrant of own use)
.
- 25. (identified use)
,
, (immediate) 가
MSDS
- 26. (undesirable use),
가
- 27. robust study summary 가
- 28. (per year),
- 29. (restriction),
.

TITLE .

CHAPTER 1.

4

- 1. Title :

 - Regulation (EEC) No 2309/93, Directive 2001/82/EC of the European Parliament and of the Council Directive 2001/83/EC of the European Parliament and of the Council
 - Council Directive 89/107/EEC 가
 - Commission Decision 1999/217/EC
 - Council Directive 70/524/EEC 가
 - Council Directive 82/471/EEC .

- 2. Title .

 - (a) Annex II
 - (b) Annex III
 - (c) Title

 - Community 3
 - Community .
 - 3 :
 -

- 30 31

3. on-site isolated transported isolated CHAPTER 4, 5
6 , Title II CHAPTER 2 3

CHAPTER 2.

5

1. , 1

Agency

1

Agency

2. on-site isolated transported isolated

, 15 16

3. , polymer

Agency

- polymer

2 w/t%

-

1

4. Agency가

6

1.

Agency

- (); 1
- Directive 67/548/EEC

2. , 3 , Agency

- 1
- Directive 67/548/EEC

- , 가

3. 2 , 108 Agency

- (a)
- (b) 가 , 18 (1)
- (c) Annex IV Section 2
- (d)
- (e)
- (f) (, 1-10 , 10-100)

4. Agency Title , 3

5. 1 4 가

6. 1 4 21 (3) 3 .

7. 1 6 가 130 (3)

6a (non - community manufacturer)

1. Community ,
Community Title
, Community
.

2.
.
가 , 33
MSDS ,
.

3. 1 2 ,
(non - Community exporter) ()
.

7

1. 5 19 ,

Community

5

2. 1

Agency

108

Agency

(a)

(b)

(c)

(d)

(e) 1

(f) 4 7

Agency가

1

Agency

가

3. Agency

Agency가

4. Agency

가

(completeness)

Agency

2 (e)

(re - collected)

5.

가

4

6.

4

Agency가

7. Agency , 5
가 5
가 가
, 10 가

8. Agency ,
(draft decision)
4 7 , Agency

9. Agency 1 8

10. 4 7 Agency , 87 ,
88 89 , (appeal)

8

1. Council Directive 91/414/EEC
Annex I Commission Regulation (EEC) No. 3600/92, Commission
Regulation (EC) No. 703/2001, Commission Regulation (EC) No.
1490/2002, Commission Decision 2003/565/EC
(active substance) Directive 91/414/EEC 6
Commission

Chapter 2 20

2. European Parliament Council

Directive 98/8/EC Annex I, IA IB, Commission Regulation
 (E/C) No./ {2 , Commission }
 (active substance) , Directive 98/8/EC 16 (2)

, Chapter 20

9

5 6 (1) (4) , 108

Agency

(a)

() Annex IV section 1

() Annex IV section 2

() Annex IV section 3

() Annex IV section 4

() Annex IV section 5

() Annex V Annex IX

() Annex I , Annex V Annex IX

robust study summaries

()

() Annex V Annex IX

()

Annex V Annex VIII

robust study summaries

(b) 13 ,

10 (Consortia)

1. Community / 가
 , , 가 /
 9 (a) (), (), () ()
 (separately)
 9 (a) (), (), ()
 ()
 9 (a)(v) (b)
 가

2. 3 1

11

1. 9 (a) (), () () ,
 (a) 1
 Annex V
 (b) 10
 Annex V Annex VI
 (c) 100
 Annex V Annex VI Annex VII
 (testing proposal)

(d) 1,000
 Annex V Annex VI Annex
 VII Annex VIII (testing
 proposal)

2. (next tonnage threshold)
 , 1 가 가
 Agency .

12

1. ,
 (qualitative or qualitative structure-activity relationship
 model) ,
 , Annex IX .

2. ,
 Annex X .
 , Annex

IX

3. (laboratory test and analyses) Directive 87/18/EEC
 (GLP, Good Laboratory Practice)
 Directive 86/609/EEC

4. ,
 (" (studies)" .)
 , ,
 ,

가

Annex IV section 2

13

1. Directive 98/24/EC 4 , 가 10
Chapter
가가

가

Annex I 2 7 가

2. , 가 가
1 가

- (a) Directive 1999/45/EC 3 (3)
- (b) Directive 1999/548/EEC Annex I
- (c) Directive 1999/45/EC Annex II Part B
- (d) Directive 1999/45/EC Annex III Part B
- (e) Title XI

(agreed entry)

(f) Annex XII , 0.1%

3. 가 가 .

() 가

() 가

() 가

() BT vPvB 가

4. 3 (a) (d) , 가
Directive 67/548/EEC , PBT vPvB
가

가 가 .
() 가
() (risk characterization)
가

5. ,
가 .
() Directive 89/109/EEC (food contact
materials)
() Directive 76/768/EEC

6. 가
, 29 MSDS

7. 가

CHAPTER 3. Polymer

14 Polymer

Polymer Title .

CHAPTER 4. isolated

15 on - site isolated

1. 1 on - site isolated on - site isolated
Agency .

2. 가 가 ,
108 Agency on - site isolated
가 .

(a) Annex IV section1

(b) Annex IV section 2

(c)

(d) ,

가

16 transported isolated

1. 1 transported isolated
transported isolated Agency .

2. 108 Agency transported isolated
가 .
- (a) Annex IV section 1
(b) Annex IV section 2
(c)
(d) ,
가
3. 1,000 transported isolated 2
Annex V .
12 가 .
4. 2 3 가 (toll or contract manufacture)
, site transported
isolated . ,
site .
- (a) , (, , ,)
, , , , , ,
/loading) (unloading),
lifecycle 가 .
- (b) 가 , .
- (c) .
- (d) , .
- (e) Directive 94/55/EC .
- (f) 가 , .

(g) site 가

(h) (a) (g)
(product stewardship)

, 9 가

17 (Consortia)

1. Community / 가 on-site isolated
transported isolated ,

가 /

15 (2)(a), (b) 16 (2)(a), (b)

(2)(c), (d) 16 (2)(c), (d) (3)

2. 3 1

, 15

CHAPTER 5.

18 Agency

1. Agency (correspondence)

Agency가

2. Agency , 3 , 9 11 15 16

21 deadline 2
phase-in , Agency deadline 3

(a) Agency 가 , Title 3
가 가

deadline
Agency 가 Agency
가

(b) Agency 가 deadline

3. Agency 30 , ,
2 가 deadline

가

Agency 가 가

4. 2 Agency , 87 , 88
89 , (appeal)

19

1. 21 , Title Community

25 (4) , 3

18 (2) Agency 가 ,

18 (2) 21 deadline 2

phase-in , deadline 3

Agency

2. 가 18 (2) 가

Agency가 , 25 (4) ,

3 Agency 가 Agency가 ,

3. 10 17 가

/ ,

/ 1 2

Community . , /

Agency가

4. 1 , 2 3 on-site isolated transported isolated

20 가

1. , 108 Agency

, Agency

(a)

(b) Annex IV

(c)

(d)

(e)

가

/

(f)

(g)

2. 10

17 가

1 (c)

CHAPTER 6. Phase - in (transitional provisions)

21 Phase - in

1. 1970년 , 1973년 3월 25일 .
 (a) Directive 67/548/EEC , , ,
 , category 1 2 1 ,
 1 Community
 (b) 1 ,
 1,000 Community phase - in
2. 1970년 , 1973년 1월 18일 ,
 100 Community phase - in
 6 .
3. 1970년 , 1973년 1월 18일 , 1975년 1월 18일
 Community phase - in
 11 .

22

1. Directive 67/548/EEC Title
 , Agency 1 .
2. 11 ,
 (next tonnage thresholds) , 9 11
 , ()
) 가 .

TITLE .

CHAPTER 1.

23

1. ,
,
가 .
2. , ,
,
(production capacities), (production or sales volume),
.
3. Agency , 10
robust study summaries
.
4. , 가 9 (a)(x)
, Title .

CHAPTER 2. Non - phase - in

24

1. 2 , 3 4 .
 2. 73
(2)(d) .
 3. Agency
, Agency .
 - (a)
 - (b) Annex IV section 2.1 2.3
 - (c) 가
 - (d) 가
 4.
 - (a) 가 , Agency
 - (b) 10 , Agency
가
robust study summaries .
- Agency , 가 9 (a) (x) ,

가

, robust study summaries

Agency

(c)

가

, Agency

25

1. 24 (5)

10

9 (a)(x)

가

2.

3.

가

2

(letter of access)

가

가

4.

Agency

- 1 Agency
- (a) 4 1 Agency 가 , Agency 가 50% 가 , robust study summaries
- (b) 가 Agency 5 deadline , Agency , robust study summaries 50%
- (c) 5 6 Agency 87 , 88 89
5. 19 (1) 가 , 4

CHAPTER 3. Phase - in

26 Phase - in

1. 21 , phase - in

Agency 108 Agency

(a) 가 , Einecs ,

(b)

(c) / deadline

(d) 가

endpoints/

(e) (d) 가 , , 가 9

(a)(x)

endpoints/

2. 1 18

- 1,000 phase - in 21

(1) deadline

- 1 phase - in 21 (2)

deadline

3. 1 21

4. , 1 phase - in
108 Agency Agency 1

5. Agency 1 4
Agency 1 4

27

1. 26 , Agency phase - in
(SIEF) 가 (participants)가

2. SIEF 가
SIEF 가 가
가 , 가

28

1. SIEF 가 26 SIEF
가 가
SIEF 가 가 ,
SIEF 가 26 (2) deadline 2

2 , 가
가

2

2. 가 SIEF 가 ,
가
가 SIEF 가 .
가

3. 가 1 , 가
가 , robust study summary
SIEF , Agency 가
summary robust study summary
가 50%
가 .

4. 3 Agency 87 , 88 89

5. 3 ,
123 .

TITLE .

29 MSDS

1. 가 Directives 67/548/EEC 1999/45/EC
 , , ,
 ,
 Annex la MSDS .
2. 13 34 , , 가
 MSDS 가
 가 .
 MSDS가 , Annex lb ,
 가 , MSDS
 가 ,
 .
3. 가 Directive 1999/45/EC 5 , 6 7
 , -가 , 1 wt% 가
 , 0.2 vol%
 Community 가 가
 , , ,
 , Annex la.4
 MSDS .
 가 가 ,
 , 가 , MSDS 가 .

5. 가

MSDS

6. MSDS

1. / /

2.

3. /

4.

5.

6.

7.

8. /

9.

10.

11.

12.

13.

14.

15.

16.

가가

,

MSDS Annex

7. ,

MSDS

8. MSDS

1

,

MSDS

(a)

가

(b)

(c) 가 가

(d)

" "

12

30 MSDS가

1. 29 MSDS 가

(a) 가 , 18 (1)

(b) 가 Title VII

가

(c) Title VIII

(d)

가

2. 1 ,

(a)

가

(b)

(c) 가 가

(d)

, 12

31

-

-

MSDS

32

MSDS

29

30

33

10

Title II

Title VI

가

Agency

TITLE .

34 가

1. .

2. 가

, , 가
가 . ,

3. , 13
1 1
Phase-in
21 deadline 13

deadline 12 .

4. , MSDS
Annex XI

가

- MSDS가 가
- 가 가

5.

- (a) MSDS 가 ,
- (b) 가

6.

7. 13 (2) (5)가 .

35

1. 5 16 가 가 MSDS가

, 2 Agency .

2. 가 108 Agency

- (a)
 - (b) 가 , 18 (1)
 - (c) Annex IV section 2
 - (d) ,
 - (e)
 - (f) 가 ,
- 가

3. 1

4. 가 , 108
Agency Agency

5. 1 4 1 가

36

1. 가 MSDS
12 34

2. 가 MSDS
6 35

TITLE . 가(Substance Evaluation)

CHAPTER 1.

37

Polymer Title 가 .

CHAPTER 2.

38

1. 39 43 , 가 가

10 가 10 17 , Agency
10 17

39

1. Annex Annex

2. 1 , 48 49

(a) Annex I
robust study summary
deadline

(b) (a)

(c)

3. Agency가

40

1.

(a) 9 가 9 , 11 12
Annex Annex

(b) 가 Annex V
Annex VIII Annex IX

2.

1 , , 48 49

3. Agency가

41

가

1.

, 39 40 , , 39 40

2. 가 , 43a
 bis (1), 56 (3) 66 (2) ,
 Commission, Agency .
 Commission, Agency,

42

1. 39 Agency

2. Agency
 120 , 39 (2)

3. phase - in , 39 (2)

(a) Annex Annex
 21 (1) deadline
 , 5

(b) Annex
 , 21 (1) deadline
 , 9

(c) 21 (3) deadline
 , (a) (b) deadline

4. 39 phase - in 가
 , Agency .

43

1. 40

Agency .

2. 가 12 , 40 (2)

.

3. , 40 phase - in

, Agency .

CHAPTER 3. 가

43a 가

, Agency 가 가

.

. 가 ,

. Agency 가

,

(rolling

plan)

.

43abis

1. 38

, , ,

,

44 , 45 46 ,

(rolling plan) .

- 가
 가 ,
 가
 - 가
 44 46

2. 1 3
 가 Agency
 2 28 3 31 , Agency
 Agency

가

3.

4. 2

가
 44 , 45 46 , ,

Agency Community GDP(gross domestic
 products)
 , 72 (1)(e) (Member State
 Committee)(, " ") . 가
 , 39 43 가

60 , 가 ,

가 , Agency 130 (3)
Commission

5. , Agency

6. 1 4 Chapter
가 .

44 가

1. , , Annex Annex
가 ,
가
48 49

2. Agency가

3. 가 Agency
12

4. 1 , 2 3 가 ,
가 12 Agency
deadline , 가가

45

- 1. Title 가 가
 . 44 가
 가 .
- 2. 가 , Agency 44
 , 130 (3) .

46

가

- 1. , 44
 , , 44 .
- 2. 가가 , 가 56
 (3) 66 (2) , Commission,
 Agency Commission,
 Agency .

CHAPTER 4.

47 On - site isolated 가

- 1. on-site isolated , 가가 .
 , 54 Annex XIII
 on-site isolated ,
 site가 .

a) 가

b) , site

2.

CHAPTER 5.

48

1. 39 , 40 44

30

2. 가 ,

가

3.

가

4. 2 3 , 44

가 가

- 가

(long term risk)

Annex XIV

- 가

66 70 가 .

49

1. 39 , 40 44 ,

Agency . Agency

2. 30 ,

Agency , . Agency

3. Agency가 30

, 1

4. Agency가 , Agency

. Agency 2 30 15

. Agency가

2

5. Agency

, 30

6. 60 가

, Agency

7. Commission , 60 130 (2)

8. 87 , 88 89 , 3 6 Agency

50

1. 가

2. 1 ,

3.

. 3 가

(security)

, 3 ,

51 Agency

2 28 ,

Agency . Agency

TITLE . 가

CHAPTER 1. 가

52 가

Title 가

53

1. , Annex XIII

- , 57 61

가

- , 55 (2)

Annex XIII 가

- 55 (1)(c)(i)

- 55 (1)(c)(i) , 18

가 , 가

- , 가가

2. 1 ,

가

3. 1 2 , Regulation (EC) No/ {PoPs}
, , Council Directive 75/442/EEC Council Directive
91/689/EEC 가 ,

4. 1 2 , 1

5. 1 2 ,

- (a) Directive 91/414/EEC
- (b) Directive 98/8/EC
- (c) Regulation (EEC) No 2309/93, Directive 2001/82/EC Directive
2001/83/EC
- (d) Directive 89/107/EEC 가
- (e) Directive 70/524/EEC 가
- (f) Decision 1999/217/EC
- (g) on-site isolated transported isolated
- (h) European Parliament Council Directive 98/70/EC
- (i)

6. 54 (a), (b) (c) 가

54 (f)

가 , 1 2

(a) Directive 76/68/EEC

(b) Directive 89/109/EEC (food contact materials)

7. 1 2 ,

- 54 (d), (e) (f) , 0.1%

- , Directive 1999/45/EC

54 Annex XIII

55 , Annex XIII .

(a) Directive 67/548/EEC 1 2

(b) Directive 67/548/EEC 1
2

(c) Directive 67/548/EEC 1 2

(d) Annex XII ,

(e) Annex XII

(f) (d) (e) ,

가 , ,
가 , 56 ,
case - by - case

55 Annex XIII

1. 54 Annex XIII
130 (3)
(a)
(b) 54
(c) (transitional arrangements)
(i) (" , sunset date") 가가
(ii) sunset date
가
deadline sunset date 18 가
sunset date 가
(d)
(e) , 가 가
가
2. 가 가
(a)

Community

(b)

3. Annex XIII , Agency

1

(a) PBT vPvB

(b) (wide dispersive use)

(c) (high volume)

Annex XIII 1

application Agency

3a. Agency가 Commission , Agency

, . Agency

3

(a) 54 (d), (e) (f)

(b) 가

Agency

4. Annex XIII , Annex XIII

Title VIII

5. Title VIII Community

Annex XIII

56 54 (d), (e) (f)

1. 54 (d), (e) (f) , 55 (3)
2 7 가 .

2. Commission , 54 (d), (e) (f)
Agency Annex XIV

3. , 54 (d), (e) (f)
Annex XIV Agency
. Agency .

4. 30 , Agency Agency

5. Agency가 , Agency 55 (3)

6. , Agency 4 30 15

7. 30 , 가
, Agency 55 (3)
. 가 , 30
, Agency
Commission .

CHAPTER 2. 가

57 가

1. Commission Title 가 .

2. Annex XIII

, Annex I, section 6 , ,
가가 .

Commission .

(a) Council Directive 96/61/EC 가

(b) 11 European Parliament Council
Directive 2000/60/EC 16
point source

(c) Council Directive 90/385/EEC, Council Directive 93/42/EEC
European Parliament Council Directive 98/79/EC

3. 2 가가 , ,
가가 .

(a)

(b)

가

(c) 59 (5) 61 (2) 3

(d) 가

4. 가가 Annex XVI ,
가가 .

5. 59 가가 .

6. / 가가 .
3 가 .

7. 가 .

- (a) 가
- (b)
- (c) 가
- (d) 가
- (e)
- (f)

8. 가 , 가 (holder of authorization)
가 가 .

58 가

1. 57 (3) 가 , Commission . , 가
18 .
가 ,
가 .

- 가 가

,

.

-

,

.

-

가

,

.

2. 가

,

가

.

, Commission

가

가

가

deadline

61

Commission

.

3. , Commission

,

가가

,

가

가

.

-

, Commission

가

.

4. Directive 96/61/EC

(environmental quality standard)

,

가

.

5. Directive 2000/60/EC 4 (1)

,

가가

.

6. Annex XVII

,

, Commission

가

.

Annex XVII

,

Commission

가

.

59 가

1. 가 Agency .
2. 가 , / 가 .
3. .
4. 가 .
 - (a) Annex IV section 2
 - (b)
 - (c) 가 가 ,
 - (d) , Annex XIII /

Annex I
5. .
 - (a) Annex XV
 - (b) 가
6. .
 - (a) Council Directive 96/61/EC 가
 - (b) 11 Directive 2000/60/EC 16
point source

(c) Directive 90/385/EEC, 93/42/EEC 98/79/EC

7. 가 , Agency가

60 가

1. 가가 ,
가 , 59 (4)(d) (5)

2. 가가 , 가
가 , 59 (4)(d) (5) 가

61 가

1. Agency . Agency
가 (Committees for Risk Assessment
and Socio-economic Analysis) 10

2. Agency 116 ,
3 가
deadline

3. , 1 59
가
가 59 가

3 가

4.

(a) 가 : /

가

(b) : 59 , 가

5. Agency

1

deadline

1 ,

Agency가

7

, Agency

15

15 ,

Commission,

2

(argumentation) Agency

2

15 ,

Agency

Commission,

6. Agency

116 ,

7. 60 (1)

deadline

, Agency

8. Commission Agency 3 가
 . 가 130 (2)

9. 가 , Commission Official
 Journal of the European Union , Agency가

10. 60 (2) , 1 deadline 5

CHAPTER 3. 가

62 가

가 가
 가

63

1. 53 (2) 1 3
 Agency , 108 Agency

2. Agency 1
 . Agency

TITLE . ,

CHAPTER 1.

64 가

1. Annex XVI ,

· , 1 , ,
·

2. Annex XVII ,

· ,
·

3. 1 2 , Regulation (EC) No/ {PoPs}

, , Directive 75/442/EEC Directive 91/689/EEC

가 ,

CHAPTER 2. (restriction process)

65

1. , , Community

가

, Annex XVI , 66 70

Annex XVI

, 130

(3)

3

, on-site isolated

2. , , 1 2

, Commission

Annex XVI

, 130 (3)

. 66 70 .

3. 55 (5) , 가 (Stockholm Convention)

UNECE Protocol on Persistent Organic Pollutants

Commission Annex XVII

Community

. Annex XVII 130 (3)

. 66 70 .

3. Directive 76/768/EEC

Annex XVI XVII .

66

1. Commission

, Community 가
, Commission Agency가 Annex XIV
가
Community (Community-wide basis) 가
, Agency
.
Agency Agency ,
가 Agency Community
Regulations Directives 가
.
, Agencies Community
(bodies)

2.

, Community 가
Annex XIV
Community (Community-wide
basis) 가 Annex XIV
Agency
.
Agency ,
가 Community Regulations
Directives 가

, Agencies Community
 (bodies)

Agency 가 (Committee for Risk Assessment)
 (Committee for Socio-economic Analysis) 가 Annex
 XIV 30 ,
 Agency 가 ,
 (suggesting restriction) 가
 , 45
 . Chapter 가 , Agency
 30 .

3. Agency 1 2 , XIV

. Agency , 3
 .

(a)
 (b) ,
 . Annex XV .

67 Agency : 가
 66 (3) 9 , Agency 가
 . 66 (3) (a)

68 Agency :

1. 66 (3) 12 ,
,
66 (3) (b)
,
. Agency
. Agency Agency가 deadline
.
2. , deadline
66
(3) (b) 68 (1)
.
3. 가 Commission
, Agency
deadline 90 .

69 Commission

1. Agency ,
가
Commission 가
67 (1) 68 (1) deadline ,
Agency , Commission .
2. Agency .
3. Agency Commission

70 Commission

1. 65 , Commission
3 가
68 deadline ,
Annex XVI .
Agency , Commission
Annex .
2. 130 (3) .

TITLE . AGENCY

71 Agency

European Chemicals Agency가 .

72

1. Agency .

(a) 74 (Management Board)

(b) 79 Executive Director

(c) 가 ,

Agency 가

(d) 가 , 가

Agency

(e) Title VI

, Title X Title VII 가

가

Agency

(f)

(Forum for Exchange of

Information on Enforcement)(, " ")

(g)

Secretariat. , Secretariat

가

Agency가

(h) Agency

(Board of Appeal)

2. 1 (c), (d) (e) (" , " ")

3.

73 Agency

1. Agency Community , Agency
Agency 가

2. Secretariat

(a) Title II , Community 가
- EU ,

(b) Title III

(c) Title VI

(d) 116 (1)

(e) Agency가 116 (1) , 90 가
가

(f) ,

(tool)

(g) , Title XII

(h)

(i) Commission , 가 ,
, Community,

, 3
(step)

3.

(a) Title VI

(b) Title VII

(c) Title VIII

(d) Title X

(e) Commission , 가 ,
, Community,

, 3

(f) Commission , ,
 ,

4. .

(a) Community

(b) , 가

(c)

(d)

(e) 가

(f)

(g) ,

74

(Management Board) 80 , Executive Director
Regulation (EC, Euratom) No 2343/2002 43 ,
(accounting officer) .

(a) 4 30 , Agency .

6 15 , European Parliament, Council, the
Commission, the European Economic and Social Committee the
Court of Auditors .

(b) 10 31 , Agency . ,
European Parliament, Council, the Commission

(c) Agency . , Community

Agency (revenue) ,

(d) Agency

Agency

93 , 94 101 Agency

Executive Director

(chairman), (members

and alternates)

1 , 가

(budgetary authority)

75

1. Commission 3 3

, Council 6 (representatives)

Commission 6 (representatives)

2.

3. 4 . 1 . , 1 (mandate)

Council Commission 6

76

1.

2.

2

1

77

1.

2. Executive Director

가

3. 72 (1)(c) (f)

78

3 2

79 Executive Director

1. Agency

, Community

Executive Director

2. Executive Director Agency

- (a) Agency (administration)
- (b) Agency
- (c) Agency Community

- (d)
- (e) (Service provider)
- (f) (statement of revenue and expenditure)
Agency
- (g) (staffs)
- (h)
- (i)

- (j) Commission , Agency 가
(arrangement)

3. Executive Director , ,

- (a) Agency Agency가
, 가 , 가 ,
, 가 ,

- (b)
- (c)
- (d)

80 Executive Director

1. Commission Official Journal of the European Union
Executive Director

2. Agency Executive Director 가

3 2

Executive Director 가

3. Executive Director 5 , 5 1

81

1. 가 Executive
Director , Agency

1

가

2. Executive Director , Agency

1

3. 1 .
4. .
5 가
3 , 가 .

(advisors)

Commission Executive Director Agency
가

(observers)

5. Agency

6.

7. 가 , Agency ,
가

8. ,
가 ,

9. .

Agency

Commission

82

1. 가 3

1

5 가

가 3

Commission Executive Director

(observers)

2.

3.

가

4.

Commission

83

가

1. 73

가

가 Annex XIV

1 (rapporteurs)

(co-rapporteurs)

가

Community

(interest)가

가

가

2.

가(experts)

가 /

가

Agency

가

가 Secretariat

가

3.

Agency

가가

Agency

, Agency

arrangement)

가

(financial

가

, Executive Director

4.

(potential service provider)가

, Agency

Executive Director

5. Agency

가(experts)

84

1.

. Executive Director

2. , Executive Director (interest)

, 1 .

3. , Executive Director

가 ,

, 가

85 (Board of Appeal)

1. Board of Appeal 2 .

2. 2

3. , , ,

Commission ,

4. 130 (2)

, Commission .

5. 가 .

86

1. , 5
, 1 .

2. ,
.

3. Agency .

4. 가 , Commission
,
.

5. 가 ,
가 ,
가 .

6. 5
,
5 .

7. 5 6 , 가
,
.

87

1. 7 , 18 , 25 (4) , 28 (2) , 49 ,
115 (4) 116 , Agency
2. 1 (suspensive effect) 가 .

88

1. .
2. , , ,
1 Agency .

89

1. 88 (2) 가 30 가
가 .
2. Agency .

90 European Communities

1. 가 , Agency가
가 , (Treaty) 230 European
Communities .

2. Agency가 , 232
European Communities .

3. Agency European Communities

91 (Ombudsman)

가 Union
, 195 agency ,
Ombudsman .

92

1. Agency , European Food Safety Authority European Agency for the
Evaluation of Medicinal Products Community Agencies
scientific Committee for toxicology, Ecotoxicology and the Environment
(CSTEE) Scientific Committee on Cosmetic Products and Non-food
Products intended for the Consumer (SCCNFP)
(Scientific Committees) Community

2. Agency가 , Agency
, 가

3.
Community, Agency , Commission

Agency

/

93 Agency

1. Agency

(a) European Communities (Commission Section)

Community

(b)

(c)

2. Agency

3. 2 15 , Executive Director

4.

5. , Executive Director가

Agency

Commission Establishment plan

3 31

6. European Communities

Commission

European Parliament Council (, "

(budgetary authority)")

7. , Commission , EU

272

Establishment plan

European Communities

- 8. Agency 가 .
Agency Establishment plan .
- 9. Agency , European
Communities .
- 10. establishment plan , 5 .
- 11. ,
, ,
가
가 ,
6 , .

94 Agency

- 1. Executive Director Agency
- 2. Agency (commitment) Agency
Agency (Accounting
Officer)
- 3. , 3 1 , Agency

- provisional accounts , Commission
- Council Regulation (EC, Euratom) No. 1605/2002
- 128 (bodies) provisional accounts
4. 3 31 , Commission
- Agency provisional accounts Court of Auditors
- European Parliament Council
5. Regulation (EC, Euratom) No. 1605/2002 129 , Agency
- provisional accounts Court of Auditors ,
- Director , Agency final accounts
6. Agency final account
7. 7 1 , Executive Director ,
- final account European Parliament, Council, Commission Court of Auditors
8. Final accounts
9. Director 9 30 Court of Auditors
10. Council , European Parliament N+2 4
- 30 N Director

95

93 (1)(b)

96

(combating fraud)

1. , European
Parliament Council Regulation (EC) No 1073/1999 Agency

2. Agency European Anti-Fraud Office(OLAF)
Interinstitutional Agreement 1999/1074/Euratom ,

3. (instruments)
, Court of Auditors OLAF가 , Agency
(agent)

97

Agency Commission , 가
. Agency , Commission
가 , Regulation (EC, Euratom) No
2343/2002 .

98 Agency

1. Agency Community (body) . , Agency 가 . , Agency 가 .
2. Agency Executive Director .
3. Agency Ispra .

99 Agency

1. Agency European Communities Agency가 .
 2. , Agency , Agency (servant) .
- European Communities .
3. Agency (servant) Agency .

100 Agency

Agency , The Protocol on the Privileges and Immunities of the European Communities가 .

101

1. Agency European Communities (officials)
(servants) . Agency

2. Commission

3. Agency Commission
Agency가
(servants)

102

(servants) , Agency 가,
가

103 3

3 , Agency
Commission

104

가 (observers) , Agency
Commission

105

Commission , Agency ,
 Commission 가
 , Agency (observers)

107

1. Agency

Community bodies .
 2. Executive Director , 가 European Food Safety
 Authority ,
 Commission
 , 가 .

Title European Food Safety Authority

3. Title 가 Agency

4. Executive Director 가 ,
 (Advisory Committee on Safety,
 Hygiene and Health Protection at Work) ,

Commission , 가 .

Title , (Advisory Committee on

Safety, Hygiene and Health Protection at Work)

108 Agency

Agency , , , Agency

, ,

,

.

TITLE .

109

Title .

(a)

(b) Directive 67/548/EEC

Directive

Directive 1999/45/EC

110 Agency

1. 109

111

Agency .

(a)

(b) Annex IV part2

(c) Directive 67/548/EEC 4 6

(d) Directive 67/548/EEC 4 (4) Directive 1999/45/EC 4

7

(e) Directive 67/548/EEC 4 (4) Directive 1999/45/EC 4

7

2.

108

3.

1

(entry)

가

(notifiers)

(entry)

4. 1

(a)

가

(b)

(entry)

(notifiers)

가 3

111

1. 110 (1)

,

, 110 (1)

Agency가

. 116 (1)

. Agency

(notifiers)

Agency 110 (4)

,

2. 1

,

,

(entry)

Agency

- (entry) , Directive 67/548/EEC Annex I

, Community 가

- 2 (notifiers)

(entry)

- 가 ,

112

1. , Community , , 1, 2 3 , Directive 67/548/EEC Annex I 가 . , , Annex XIV Agency , .
2. , , Agency . Directive 67/548/EEC 4 (3) Commission .

113 (transitional arrangements)

110 21 (1) deadline .

TITLE XI.

114

1. , 108 가
 , 10
 1 Commission .
 , 1 , 5 .
2. Agency 10 1 Commission
 , 1 131 (2) 5
3. Commission , 1 2 ,
 10 1 .
 , 1 131 (2) 6

115

1. European
 Parliament Council Regulation (EC) No 1049/2001 Agency가
 . Agency 73 (2)(d) ,
2. Regulation (EC) No 1049/2001 Agency 가
 , Agency , Regulation (EC)
 No 1049/2001 4 (4) 3 .

Agency , , , , 30 , , 가 , , Agency Commission 가 , , Agency가 , Agency . Agency 15 , 87 , 88 89 , (Board of Appeal) (suspensive effect) 가 . (Board of Appeal) 30

3. European Parliament Council Directive 2003/4/EC 가 (suspensive effect)

3a. 가 , 가 , Agency 가

4. Agency Regulation (EC) No 1049/2001 4 Directive 2003/4/EC 4 , 116 , Agency , Agency Regulation (EC) No 1049/2001 4 (4) (5)

5. Regulation (EC) No 1049/2001 8 Agency
 87 , 88 89 ,
 (Ombudsman) (Board of Appeal)

6. 6 , Regulation (EC) No
 1049/2001 .

116

1.
 - (a)
 - (a') Directive 67/548/EEC IUPAC
 - (b) 가 , Eines
 - (c) , (pathways)
 - (d)
 - (e) Annex I derived no-effect level (Dnel) predicted
 no-effect concentration (Pnec)
 - (f) ,
 / 가
 - (g) Annex section 4
 - (h) / 2 가
 MSDS
 - (i) Annex VII Annex VIII ,
 , ,
 - (j)

2. 115 (2)

- (a)
- (b)
- (c)
- (d)

, Agency

3. 115

117 3

115 116 , Agency가

European Parliament Council Regulation (EC) No 304/2003

181a (3) Community 3 3

(management)

- 3

TITLE XII.

118

European Commission Agency

119

120

121

73 (2)(f)

Agency가

TITLE .

122

123

1.

8

Commission

2.

가

124

122

123

7 1

Agency

Agency

Commission

TITLE .

125

Community

126

1.

Commission, Agency

2. Commission 130 (2)

90

a)

b)

3. 2 a)

가

Commission

3

Annex XIV

Agency

Community

4. 2 a)

, Commission

127

, Agency Commission

128 Annexes

Annexes 130 (3)

129

130 (3)

130

1. Commission 가 , Commission

2. , Decision 1999/468/EC 3 advisory
 procedure가 Decision 7 (3) 8 .

3. , Decision 1999/468/EC 5 regulatory
 procedure가 Decision 7 (3) 8 .

4. Decision 1999/468/EC 5 (6) 3 .

131 Agency

1. Commission 3

가 Agency

, Agency

, Commission Agency

, Agency

80

Agency

가 Executive Director

, Executive Director

2.

18

, Agency

Executive Director

Agency

가

가

Commission

3.

2

2

18

, Commission

Agency

132

18

, Commission

, Annex XVI

(a) Regulation (EEC) No 793/93

11

Community

,

Community

가

,

가

(b) Directive 76/769/EEC

,

,

133

1.

12

, Commission

가

,

10

Commission 130 (3)

2. Commission 130 (3)

Polymer

, 14 37

- Polymer

Polymer

3. 114 (3)

, 1 10

, Commission 130 (3)

[(quantitative)

structure-activity relationships((Q)Ars)]

1 10

Annex V

134

Directives 76/769/EEC, 91/157/EEC, 93/67/EEC, 93/105/EEC
2000/21/EC Regulations (EEC) No 793/93 (Ec No 1488/94

135 Directive 1999/45/EC

Directive 1999/45/EC 14 .

137

1. Official Journal of the European Union 20

2. Title II Title XII 6 .

3. 81 82 1 .

4. 66 70 18 .

5. 44 , 45 46 2 .

, [] .

European Parliament

Council

[..]

[..]

3

REACH

(1)

: 가

(Basel Convention on the Control Transboundary Movements of Hazardous Wastes and their Disposal)

- 1970 가

, 1980

-

가
(UNEP) , 1987 12 42

-

- , 가

-

,

,

.

- 1987. 12. 가
(42/183,184,187)
- 1989. 3. (,)
- , 105 (Final Act)
- 1992. 5. (가 : 94.2.28, :94.5.29)
- :
- 2001.5. 가 : 146 (:)

- 가
-
- * , 가
-

- 가 ,
- 29 , 6) (
- (1)
- I (45) 가
- 1998 (Annex VIII)
- . . 가

- (Other Wastes) : (가)
- ,
- 1997 9 IAEA Joint-Convention on
the Safety of Spent Fuel Management and on the Safety of
Radioactive Waste Management가
- .
- (3 , 4)
-
- (3)
- (4)
-
-
-
-
-
- (4 5)
- 가 (6 8)
- 가 (6)
- ,
-
-
-
- 가(-)
- , (60)
-
- (9)

- 가가 ,

-

- (11)

- 4 5

.) OECD

1 (92.12.3-4, Piriapolis) (1/22)

2 (94.3.21-25,)
- OECD 가 Non-OECD 가 (/12)

3 (95.9.18-22,)
- : Ban Amendment
- /12 :
98.1.1 ()

2001.5. 25 (62)

4 (98.2.23-27,)

-

-

▪ (), ()

▪ 3

(/1, /12)

▪ A B ,
(60)

5 (99.12.6 - 10,)

-

▪ 가

-

▪ 10 “ ” (ESM)

▪ , , , ,
,

(2) (POPs; Persistent Organic Pollutants)

: “ Stockholm Convention on Persistent Organic Pollutants”

: , 30 , 6

: (Precautionary Principle)

(POPs)

POPs(Persistent Organic Pollutants)

(endocrine disrupter)

가

: 2004 5 17

Aldrin, Chlordane, DDT, Dieldrin, Dioxin, Endrin, Furans, Heptachlor,
Hexachlorobenzene, Mirex, PCBs, Toxapheme

12가 DDT 11가

DDT

<POPs >

(CAS)		
Aldrin (309 - 00 - 2)		: ('91) ('99)
		: ('69)
Chlordane (57 - 74 - 9)		: ('91) ('99)
		: ('69)
DDT (50 - 29 - 3)		: ('91)
		: ('69)
Dieldrin (60 - 57 - 1)		: ('91) ('99)
		: ('70)
Endrin (72 - 20 - 8)	,	: ('91) ('99)
		: ('69)
Hexachlorbenzene (118 - 74 - 1)	, ,	
Heptachlor (76 - 44 - 8)		: ('91) ('99)
		: ('79)
Mirex (2385 - 85 - 5)	,	
PCB (1336 - 36 - 3)	(),	: ('96)
		: '79.8.30
Toxaphene (8001 - 35 - 2)		: ('91)
		: ('82)
Dioxins	(,)	: ('97)
Furans		: ('97)

		, , HCB, PCB
()	-	(, , ,)
	-	, 2 (, ,)
	-	()
	-	
	-	-가
	-	
	-	- ,
	-	
	-	()
	-	
	-	가 (), ()
	-	
	-	smouldering
	-	

(3) (PIC,)

1989 (PIC ; Prior Informed Consent) 가

'98.3.

(PIC)

PIC

PIC

가가

: 2004 2 24

90

6

2 PIC

1

III

III

,

6

III

.

III

(HS Code)

,

III

(MSDS)

1

1

UNEP

FAO

,

UNEP FAO가

가 가 3/4

3/4

90

III

,

,

III

50 , , , 가 가 90

III(PIC)

- (17): 2,4,5-T, Aldrin, Captafol, Chlordane, Chlodimeform, Chlorobenzilate, DDT, Dieldrin, Dinoseb & dinosebsalts, 1,2-dibromoethane(EDB), Fluoroacetamide, HCH(mixed isomers), Heptachlor, Hexachlorobenzene, Lindane, Mercury compounds, Pentachlorophenol
- (5): Monocrotophos, Methamidophos, Phosphamidon, Methyl-parathion, Parathion
- (5): Crocidolite, Polybrominated biphenyls(PBB), Polychlorinated biphenyls(PCB), Polychlorinated terphenyls(PCT), Tris (2,3 dibromopropyl) phosphate

(1)

(volatile organic compounds: VOCs)

39 1

2001 - 36 (2001.3.8)

37

(2001 - 36 , 2001.3.8)

			CAS No.	
1		Acetaldehyde	CH3CHO	75-07-0
2		Acetylene	C2H2	74-86-2
3		Acetylene Dichloride	C2H2Cl2	540-59-0
4		Acrolein	C3H4O	107-02-8
5		Acrylonitrile	C3H3N	107-13-1
6		Benzene	C6H6	71-43-2
7	1,3 -	1,3 - Butadine	C4H6	106-99-0
8		Butane	C4H10	106-97-8
9	1 - , 2 -	1 - Butene, 2 - Butene	C4H8[CH3CH2CHCH2] C4H8[CH3(CH)2CH3]	106-98-9 107-01-7
10		Carbon Tetrachloride	CCl4	56-23-5
11		Chloroform	CHCl3	67-66-3
12		Cyclohexane	C6H12	110-82-7
13	1, 2 -	1,2 - Dichloroethane	C2H4Cl2[Cl(CH2)2 Cl]	107-06-2
14		Diethylamine	C4H11N[(C2H5)2NH]	109-89-7
15		Dimethylamine	C2H7N	124-40-3
16		Ethylene	C2H4	74-85-1
17		Formaldehyde	HCHO	50-00-0

				CAS No.
18	n -	n - Hexane	C6H14	110 - 54 - 3
19		Isopropyl Alcohol	C3H8O[(CH3)CHOHCH3]	67 - 63 - 0
20		Methanol	CH3OH	67 - 56 - 1
21		Methyl Ethyl Ketone	C4H8O[CH3COCH2CH3]	78 - 93 - 3
22		Methylene Chloride	CH2Cl2	75 - 09 - 2
23	(MTBE)	Methyl Tertiary Butyl Ether	CH3OC(CH3)2CH3	1634 - 4 - 4
24		Propylene	C3H6	115 - 07 - 1
25		Propylene Oxide	C3H6O	75 - 56 - 9
26	1, 1, 1 -	1,1,1 - Trichloroethane	C2H3Cl3	71 - 55 - 6
27		Trichloroethylene	C2H2Cl3	79 - 01 - 6
28		Gasoline	-	86290 - 81 - 5
29		Naphtha	-	8030 - 30 - 6
30		Crude Oil	-	8002 - 5 - 9
31	()	Acetic Acid	C2H4O2	64 - 19 - 7
32		Ethylbenzene	C8H10	100 - 41 - 4
33		Nitrobenzene	C6H5NO2	98 - 95 - 3
34		Toluene	C7H8	108 - 88 - 3
35		Tetrachloroethylene	C2Cl4	127 - 18 - 4
36	(o -, m -, p -)	Xylene	C8H10	1330 - 20 - 7 (95 - 47 - 6 108 - 38 - 3 106 - 42 - 3)
37		Styrene	C8H8	100 - 42 - 5

: CAS No. Chemical Abstracts Service Registry Numbers .

(2)

가 , -
가
가
, 25

1.	14.
2.	15.
3.	16.
4.	17.
5.	18.
6.	19.
7.	20.
8.	21.
9.	22.
10.	23.
11.	24.
12.	25. 1 - 3
13.	

(3)

1992 5 5 가
 「 가
 1992 12 8 -
 1994 2 28 가 가 5 29
 1995 1 1
 - 가 1996 12 (OECD) 가
 OECD 1997 8 28 가
 가
 - OECD
 1998
 7 15
 -
 - 가 PCB
 - 가 () 가
 가 ,
 (Green Lists of Wastes)/ B
 - , 가 가
 가

	OECD		
	가 , (가)	가 , (가)	
	3	-	
	- 30 o : o : o : (/)	- 가 - 60 ()	- , 가 7 - 5 가 30 - , 가 10 , 가 - 가
	3	(60)	- 10
	30	(60)	- 10
	- 가	-	-

(4) GLP

가 , .
 , GLP(Good Laboratory Practice)
 .
 OECD가 GLP ,
 1998 GLP
 , ,
 GLP(Good Laboratory Practice)
 , GLP
 . ,
 GLP (,
), LG (), ,
 , () , 5
 가 .
 GLP GLP " ,
 ()"
 GLP 가
 , GLP ,
 GLP

(1991.2.2)

(,

35,661)

7

,

.

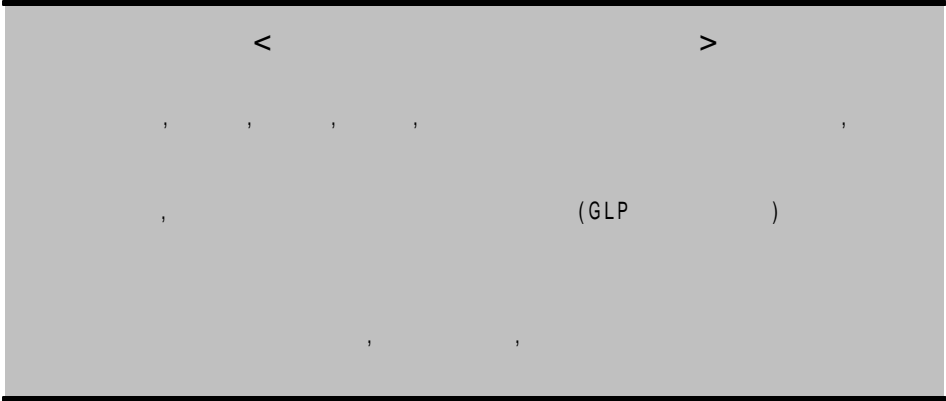

"

,

, ,

47

49

"

()"

(1991.2.2)

(,

35,661) "

"

30

(" ")

, 가
1998

,

409

47

, 2

OECD

가

"

가 (SIDS, Screening Information Data Set)"

7

OECD

가

1,000

(High Production

Volume, HPV)

가

가

OECD

가

가

2000. 6

(2000 - 2004)

2004

가

가

가가 가

(5)

,
4 8

1

"

1

■ 본 보고서는 산업자원부에서 지원하는
'청정생산기술개발보급사업'으로 수행한 결과입니다.

■ 본 보고서는 국가청정생산지원센터 홈페이지(www.kncpc.re.kr)의
'자료실' 에서 pdf 파일로 보실 수 있습니다.